



# Pressure relief dampers

## Type ARK-2

TROX GmbH  
Heinrich-Trox-Platz  
47504 Neukirchen-Vluyn  
Germany  
Phone: +49 (0) 2845 2020  
Fax: +49 (0) 2845 202265  
E-mail: [trox@trox.de](mailto:trox@trox.de)  
<http://www.troxtechnik.com>

### Product overview

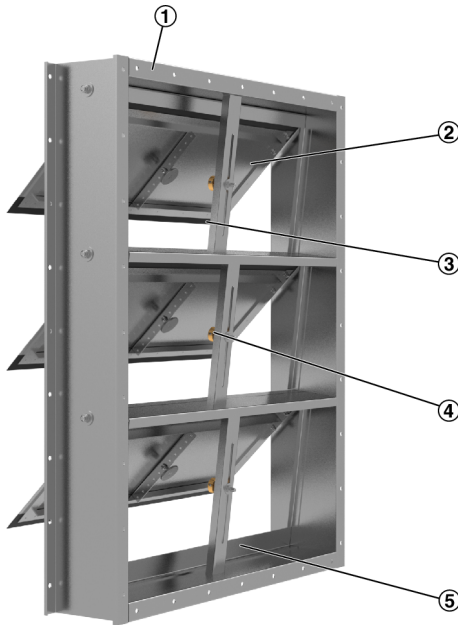

Fig. 1: Schematic illustration of ARK-2

- |   |               |   |                             |
|---|---------------|---|-----------------------------|
| ① | Casing        | ④ | Centre mullion              |
| ② | Blades (open) | ⑤ | Travel stop (angle section) |
| ③ | Seal          |   |                             |

## Important notes

### Information on the installation manual

This manual enables operating or service personnel to correctly install the product described below and to use it safely and efficiently.

It is essential that these individuals read and fully understand this manual before starting any work. The basic prerequisite for safe working is to comply with the safety notes and all instructions in this manual.

The local regulations for health and safety at work and general safety regulations also apply.

### Qualified staff

The work described in this manual has to be carried out by individuals with the qualification, training, knowledge and experience described below:

#### HVAC technician

HVAC technicians are individuals who have sufficient professional or technical training in the field they are working in to enable them to carry out their assigned duties at the level of responsibility allocated to them and in compliance with the relevant guidelines, safety regulations and instructions. HVAC technicians are individuals who have in-depth knowledge and skills related to HVAC systems; they are also responsible for the professional completion of the work under consideration.

HVAC technicians are individuals who have sufficient professional or technical training, knowledge and actual experience to enable them to work on HVAC systems, understand any potential hazards related to the work under consideration, and recognise and avoid any risks involved.

### Limitation of liability

The information in this manual has been compiled with reference to the applicable standards and guidelines, the state of the art, and our expertise and experience of many years.

The manufacturer does not accept any liability for damages resulting from:

- Non-compliance with this manual
- Incorrect use
- Operation or handling by untrained individuals
- Unauthorised modifications

The actual scope of delivery may differ from the information in this manual for special constructions, additional order options or as a result of recent technical changes.

### Copyright

This document, including all illustrations, photos, etc., is protected by copyright.

Any use of this document without the written consent of the manufacturer is an infringement of copyright; this applies in particular to disclosing this document to third parties, to publishing, copying, microcopying, or translating content, and to saving content on electronic systems or modifying it.

Violators will be held liable for any damage. The right to further claims remains reserved.

### Personal protective equipment

Personal protective equipment must be worn for all work in order to reduce health or safety hazards to the minimum.

The appropriate protective equipment for a job must be worn for as long as the job takes.

### Correct use

Pressure relief dampers are used to reliably control pressure peaks in air conditioning systems. They open and close automatically when the maximum differential pressure is exceeded. When the differential pressure drops below approx. 30 Pa, the blades close again.

**Incorrect use****WARNING!****Danger due to incorrect use!**

Incorrect use of the pressure relief damper can lead to dangerous situations.

Never use the pressure relief damper:

- in areas with potentially explosive atmospheres
- for process air
- outdoors without sufficient protection against the effects of weather
- in humid rooms
- in rooms with aggressive or dust-laden air

- Storage temperature: –10 to 50 °C
- Relative humidity: 95 % max., non-condensing

**Transport and packaging****Transport****CAUTION!****Danger of injury from sharp edges, sharp corners and thin sheet metal parts!**

Sharp edges, sharp corners and thin sheet metal parts may cause cuts or grazes.

- Be careful when carrying out any work.
- Wear protective gloves, safety shoes and a hard hat.

Use only lifting and transport gear designed for the required load. Always secure the load against tipping and falling.

Upon delivery, carefully remove the packaging and check the damper for transport damage and completeness.

**Storage**

Please note:

- Store the unit only in its original packaging
- Protect the unit from the effects of weather
- Protect the unit from humidity, dust and contamination

Installation

General safety notes

**! CAUTION!**

**Danger of injury from sharp edges, sharp corners and thin sheet metal parts!**

Sharp edges, sharp corners and thin sheet metal parts may cause cuts or grazes.

- Be careful when carrying out any work.
- Wear protective gloves, safety shoes and a hard hat.

Personnel:

- HVAC technician

**! NOTICE!**

**Contamination or damage will impair the function of the damper.**

Protect the damper from contamination and damage.

Please note:

- Installation should be vertical and without torsion
- Installation only into horizontal ducts, with the blades horizontal
- Note the airflow direction
- Duct connection on one side or on both sides
- Dampers that are not screw-fixed to the wall or ceiling slab require suspensions.
- The function of the damper must be checked before installation.

Installation

**! NOTICE!**

**Risk of damage due to incorrect use.**

Do not use the ARK-2 pressure relief damper in areas where freezing condensate may impair the function of the damper, e.g. in external walls.

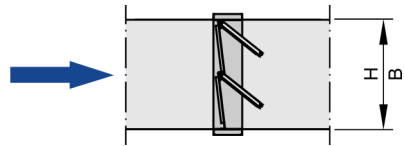

Fig. 2: Horizontal airflow

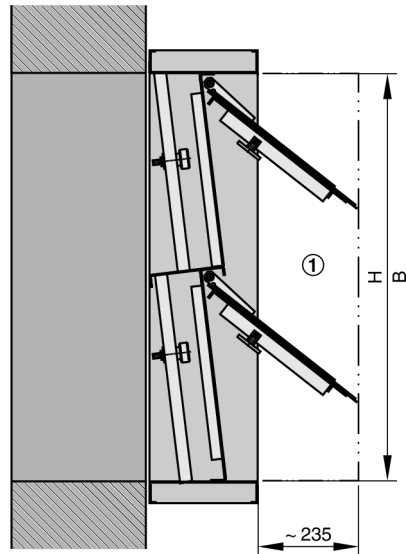

Fig. 3: Wall installation without installation subframe

① Blade movement area must be kept clear

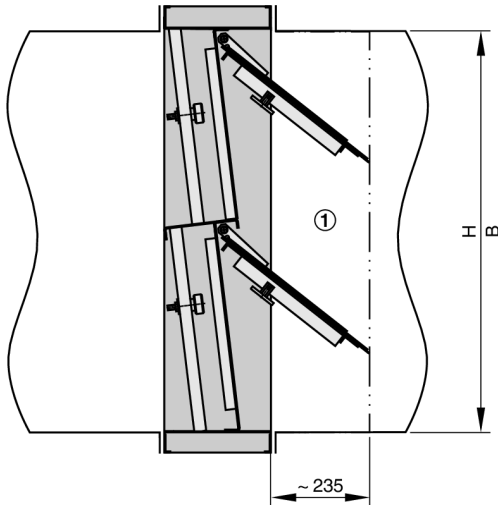

Fig. 4: Duct installation

① Blade movement area must be kept clear

Fix the damper with suitable screws (by others);  
flange holes  $\varnothing 9.5$  mm.

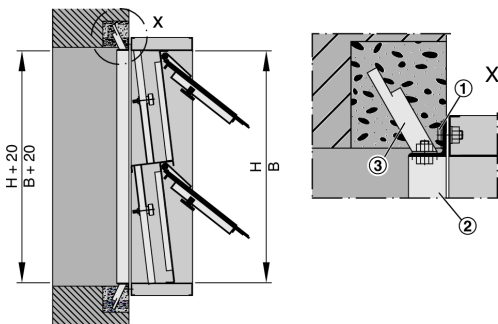

Fig. 5: Wall installation with installation subframe  
(steel/stainless steel construction)

- ① Threaded stud
- ② Fixing tab
- ③ Installation subframe

Items 1 to 3 are included in the installation sub-  
frame supply package

Installing the installation subframe

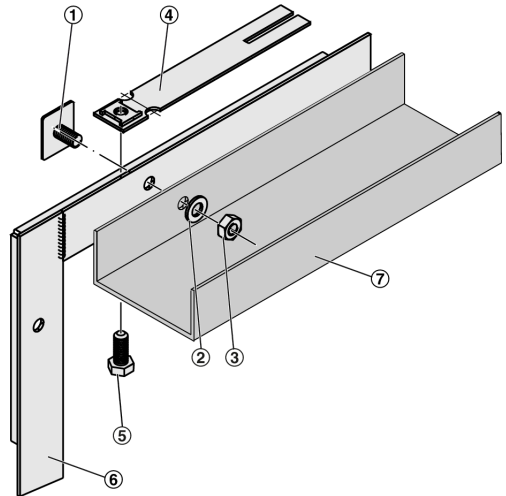

Fig. 6: Installation subframe and damper assembly

- ① Threaded stud
- ② Washer
- ③ Hexagonal nut
- ④ Fixing tab
- ⑤ Hexagon head screw
- ⑥ Installation subframe
- ⑦ Damper casing

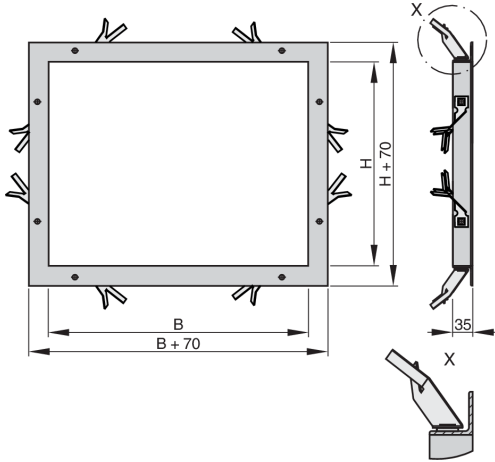

Fig. 7: Bend and spread the fixing tabs before installation

**Connecting the duct**

Use screws to attach the damper to the ducting. The damper casing has flange holes for duct connection.

Seal the joint between the casing flange and the duct in order to avoid pressure loss. Use sealing tape, for example, and clamps or additional screws, if necessary.



*The movement of the damper blades must not be obstructed by any attachment.*

**Commissioning and maintenance**

**Commissioning**

**Personnel:**

- HVAC technician

Permanent magnets are used to keep the blades closed up to the maximum differential pressure. The pressure required to open the blades is factory set as ordered; the maximum differential pressure is given on the rating plate of the pressure relief damper.

The actual system conditions cannot be considered at the time of the factory setting which is why deviations might occur on site.

To avoid malfunctions, any disturbing effects should be kept to a minimum, and there should be a sufficient difference between the permitted maximum differential pressure and the 'normal' system pressure.

The maximum differential pressure cannot be changed by others.

Check before commissioning whether the blades can move freely and whether the operating range is clear.

**Maintenance**

Pressure relief dampers are maintenance-free with regard to wear but must still be included in the regular cleaning of the ventilation system.

**Technical data**

| Data   | Value     | Unit |
|--|-----------|------|
| Max. pressure  | 5000      | Pa   |
| Operating temperature  | 0 – 80    | °C   |
| Factory set maximum differential pressure for width 200 – 600 mm                     | 50 – 1000 | Pa   |
| Factory set maximum differential pressure for width 601 – 1000 mm                    | 50 – 600  | Pa   |
| Maximum airflow velocity at 50 Pa  | 2         | m/s  |
| Closed blade air leakage (against the intended airflow direction) to EN 1751 (class) | 4         |      |
| Casing air leakage to EN 1751 (class)  | C         |      |

For more technical data see the technical leaflet.

